

SERENE RINGmaster™



Operating Guide Manuel de l'utilisateur

Model RF-110

Modèle RF-110



Thank you for purchasing this Ringmaster; please read this operating guide carefully before use and keep it for future reference. RF-110 is engineered to work with both home phone and cell-phone. If you have any questions regarding this product, please contact our Customer Care Department.

IMPORTANT SAFETY INSTRUCTIONS

WARNING – When using telephone equipment or electric appliances, basic precautions should always be followed to reduce the risk of fire, electrical shock and injury to persons, including the following:

1. Read all the instructions before using the appliance.
2. To reduce the risk of injury, close supervision is necessary when an appliance is used near children.
3. Do not contact moving parts or any exposed metal surface.
4. Only use attachments recommended or sold by the manufacturer.
5. Do not use outdoors. Do not use near water, for example, near a bath tub, wash bowl, kitchen sink or laundry tub, in a wet basement or near a swimming pool.
6. To disconnect, turn all controls to the off position, then remove plug from outlet.
7. Do not unplug by pulling on cord. To unplug, grasp the plug, not the cord.
8. Unplug from outlet when not in use and before servicing or cleaning.
9. Do not operate any appliance with a damaged cord or plug, or after the appliance malfunctions or is dropped or damaged in any manner. Return appliance to the nearest authorized service facility for examination, repair, or electrical or mechanical adjustment.
10. Use only the power cord and batteries indicated in the manual. Do not dispose of batteries in fire. They may explode. Check local codes for possible special disposal instructions.
11. Always disconnect AC adapter and phone cord before replacing batteries.
12. Plug any power adapter to the socket-outlet that near the equipment and should be easily accessible.
13. Avoid using any telephone product during an electrical storm. There may be a remote risk of electric shock from lightning.
14. Do not use the telephone to report a gas leak in the vicinity of the leak.

“SAVE THESE INSTRUCTIONS”

PACKAGE CONTENTS:

Your package includes all the items as shown here. If there is anything missing, please contact our Customer Care Department immediately

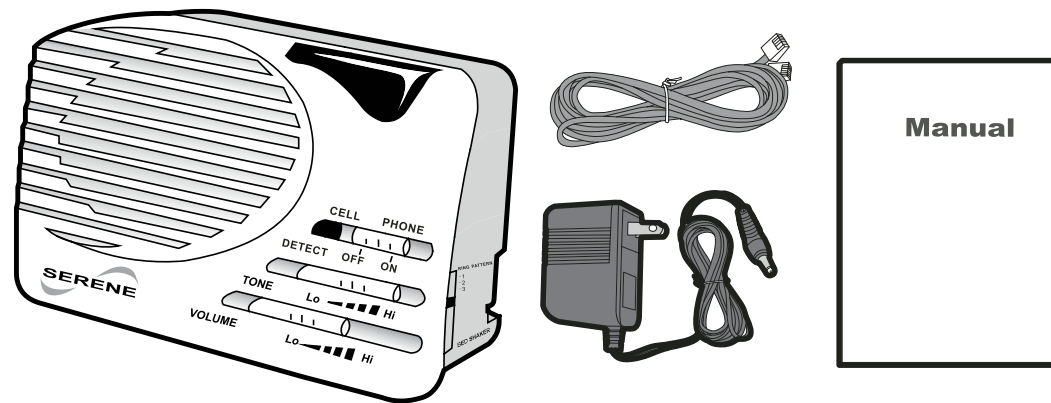

FEATURE IDENTIFICATION MODEL RF-110

1. Cell-phone detection On indicator
2. Cell-phone detection On – Off switch
3. Ring tone selection
4. Ring volume selection
5. Ring pattern selection
6. Bed-shaker (sold separately) connection
7. Call flasher – flashes when your phone rings
8. Battery compartment (for back-up power, optional) & cell-phone strap on rear of unit

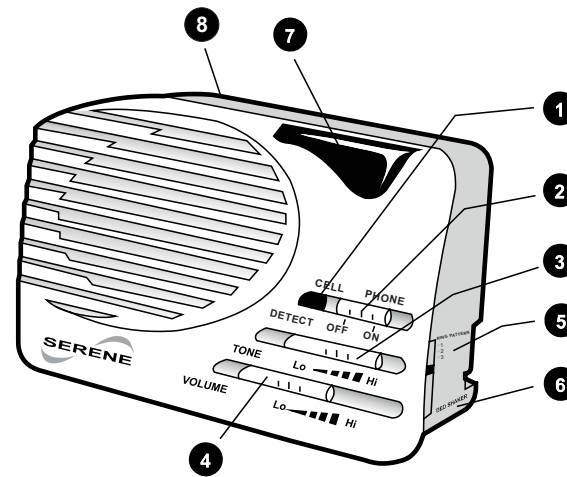

CONNECTION

Connect your Ringmaster to the phone jack and phone (optional) as shown. When finished, test Ringmaster by asking someone to call you; if it rings, your connection is complete. If not, check all connections again.

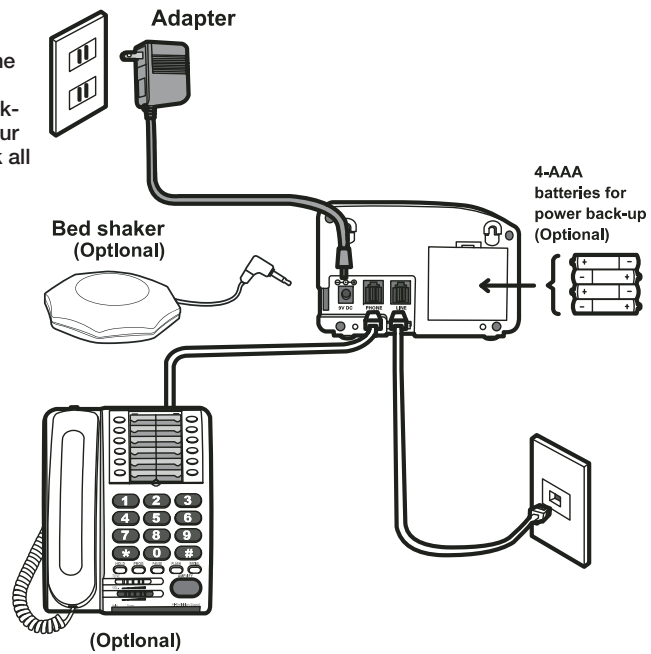

CELL-PHONE CONNECTION

Set your cell-phone to vibration mode or vibration and ringing mode because RF-110 Ringmaster senses cell-phone vibration for detection.

Strap your cell-phone (optional) to the Ringmaster as shown; set the RF-110 Cell-Phone detection switch to ON .

When finished, test Ringmaster by asking someone to call your cell-phone; when your cell-phone vibrates, Ringmaster outputs a unique ring tone to indicate this is a cell-phone call. The built-in flasher, and the optional shaker are also activated. If not, check all settings again. (Note: The cell-phone ring tone is fixed).

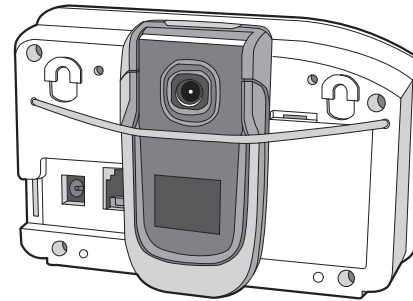

OPERATION

Your Ringmaster has been pre-set for optimum operation. In general, no adjustment is needed. But, you can tune its operation to best suit your hearing. While the phone is ringing follow these steps for adjustments.

1. Volume adjustment---slide the volume control lever to reach a comfortable ring level.
2. Ring Pattern selection---slide the control to choose a ringing pattern that is most pleasant to you.
3. Ring Tone adjustment---simply slide the control to choose a tone that enables you to hear the best.

BED-SHAKER (OPTIONAL)

If you don't want to miss any calls while you are asleep, plug in a Bed-shaker (Serene bed-shaker Model BS-100 only, sold separately). The bed-shaker will vibrate in sync with the ringing of your phone to notify you of any incoming calls.

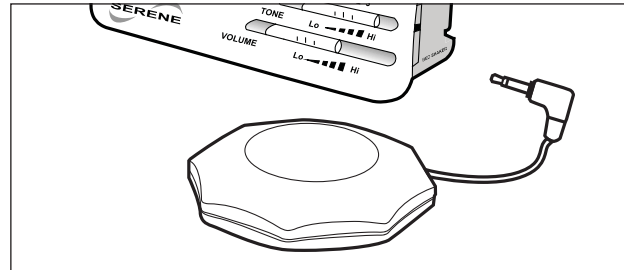

SPECIFICATIONS:

MAXIMUM LOUDNESS	98DBA
LOUDNESS CONTROL	SLIDE CONTROL
AC ADAPTER OPERATION	9VDC, 800 MA
BATTERY BACK-UP OPERATION	4 AAA SIZE ALKALINE BATTERY (NOT PROVIDED)
INPUT JACK	RJ-11 FOR PHONE LINE CONNECTION
OUTPUT JACK	RJ-11 FOR CONNECTION TO PHONE (OPTIONAL CONNECTION)
CELL-PHONE DETECTION METHOD	SENSES CELL-PHONE VIBRATION
UNIT SIZE	7.25" X 3.5" X 1.9"
WEIGHT	1.15 LBS

WARRANTY SERVICE INFORMATION

Your Ringmaster comes with one-year limited warranty. We warrant during this warranty period, from the date of purchase, to the original consumer, the Ringmaster to be free from defects in materials and workmanship under intended home use. In the event that it fails to function properly within one year of original purchase due to defects in materials or workmanship, return the unit (freight prepaid) with proof of purchase (sales receipt or packing slip, no exceptions) to Serene Innovations. Serene Innovations will either repair or replace the unit (with a refurbished unit or unit of equal condition) and return it to you (using UPS/USPS ground shipping) at no cost to you if the unit is returned within 30 days of purchase. If the unit is returned after 30 days of purchase but within the warranty period, there will be a warranty handling charge of \$9.95 for each return.

This warranty does not apply to any product that has been accidentally damaged, abused, misused or negligent, used on electrical frequency or voltage other than marked on product and/or described in manual. Defects or errors caused by unauthorized alterations, repairs, and/or tampering are also not covered by this warranty.

This Warranty gives you specific legal rights, and you may also have other legal rights that vary from state to state.

If a defect covered by this warranty should occur, promptly contact a Customer Care Representative by phone or log onto www.sereneinnovations.com to obtain a Return Authorization Number (RAN) and shipping instructions before shipping the product to us. Any shipment without a RAN will not be accepted and will be returned to you at your expense. Any authorized returned product must be accompanied with proof of purchase and a brief explanation of the problem.

For out of warranty repair and service, please contact our Customer Care Department for instructions

FCC INFORMATION

This equipment complies with Part 68 of the FCC Rules. On the equipment is a label that contains, among other information, the FCC registration number and ringer equivalence number (REN) for this equipment. If requested; this information must be provided to your telephone company.

This equipment uses the following Universal Service Order Codes ("USOC") jacks: RJ-11. Connection to the telephone network should be made by using standard modular telephone jack type RJ11.

The REN is useful to determine the quantity of devices you may connect to your telephone line and still have all of those devices ring when your telephone number is called. In most, but not all areas, the sum of the RENs of all devices connected to one line should not exceed five (5.0). To be certain of the number of devices you may connect to your line, as determined by the REN, you should contact your local telephone company to determine the maximum REN for your calling area.

If your telephone equipment causes harm to the telephone network, the telephone company may discontinue your service temporarily. If possible, they will notify you in advance. But if advance notice is not practical, you will be notified as soon as possible. You will be informed of your right to file a complaint with the FCC.

Your telephone company may make changes in its facilities, equipment, operations or procedures that could affect the proper functioning of your equipment. If they do, you will be notified in advance to give you an opportunity to maintain uninterrupted telephone service.

In the event this equipment should fail to operate properly, disconnect the unit from the telephone line. Try using another FCC approved telephone in the same telephone jack. If the trouble persists, call the telephone company repair service bureau.

FCC INFORMATION

If the trouble does not persist and appears to be with this unit, disconnect the unit from the telephone line and discontinue use of the unit until it is repaired. For repair or warranty information, please contact Serene Innovations, Inc. at 562- 407 5400. Please note that the telephone company may ask that you disconnect this equipment from the telephone network until the problem has been corrected or until you're sure that the equipment is not malfunctioning.

There are no user serviceable parts in this equipment.

This equipment may not be used on coin service provided by the telephone company. Connection to party lines is subject to state tariffs. Contact the state public utility commission, public service commission for information.

If your home has specialty wired alarm equipment connected to the telephone line, ensure the installation of this equipment does not disable your alarm equipment. If you have questions about what will disable alarm equipment, consult your telephone company or a qualified installer.

Modification: Any modification not expressly approved by the manufacturer of this device could void the user's authority to operate the device.

NOTICE: The Industry Canada label identifies certified equipment. This certification means that the equipment meets telecommunications network protective, operational and safety requirements as prescribed in the appropriate Terminal Equipment Technical Requirements document(s). The Department does not guarantee the equipment will operate to the user's satisfaction.

FCC INFORMATION

Before installing this equipment, users should ensure that it is permissible to be connected to the facilities of the local telecommunications company. The equipment must also be installed using an acceptable method of connection. The customer should be aware that compliance with the above conditions may not prevent degradation of service in some situations.

Repairs to certified equipment should be coordinated by a representative designated by the supplier. Any repairs or alterations made by the user to this equipment, or equipment malfunctions, may give the telecommunications company cause to request the user to disconnect the equipment. Users should ensure for their own protection that the electrical ground connections of the power utility, telephone lines and internal metallic water pipe system, if present, are connected together. This precaution may be particularly important in rural areas.

Caution: Users should not attempt to make such connections themselves, but should contact the appropriate electric inspections authority, or electrician, as appropriate. The REN for this equipment as stated on the IC regulatory label located on the bottom of the product.

NOTICE: The Ringer Equivalence Number (REN) assigned to each terminal device provides an indication of the maximum number of terminals allowed to be connected to a telephone interface. The termination on an interface may consist of any combination of devices subject only to the requirement that the sum of the Ringer Equivalence Numbers of all the devices does not exceed 5.